

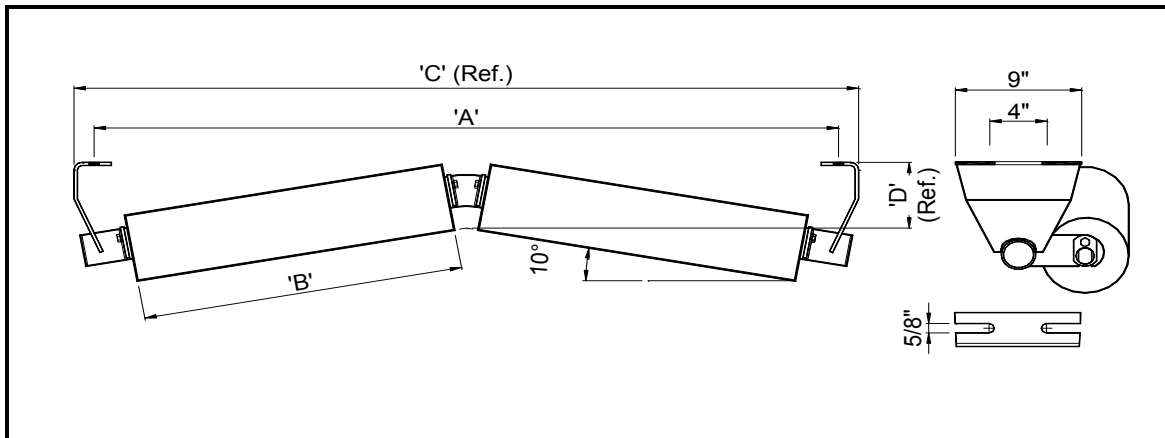

## 10° INVERTED V RETURN IDLER



### 5" ROLL

| BELT WIDTH | IDLER PART NUMBER      | ROLL PART NUMBER  | A         | B             | C         | D            | IDLER WEIGHT | ROLL WEIGHT | ROLL ROTATING WEIGHT | SHAFT Ø  | BRG TYPE    |
|------------|------------------------|-------------------|-----------|---------------|-----------|--------------|--------------|-------------|----------------------|----------|-------------|
| 24         | MC5-2410-INVRET        | MC-VR-5-24        | 33        | 11 3/4        | 36        | 4 6/8        | 39           | 14          | 11                   | 1        | 6205        |
| <b>30</b>  | <b>MC5-3010-INVRET</b> | <b>MC-VR-5-30</b> | <b>39</b> | <b>15 3/4</b> | <b>42</b> | <b>4 7/8</b> | <b>48</b>    | <b>17</b>   | <b>13</b>            | <b>1</b> | <b>6205</b> |
| 36         | MC5-3610-INVRET        | MC-VR-5-36        | 45        | 18 3/4        | 48        | 4 7/8        | 55           | 20          | 15                   | 1        | 6205        |
| <b>42</b>  | <b>MC5-4210-INVRET</b> | <b>MC-VR-5-42</b> | <b>51</b> | <b>22</b>     | <b>54</b> | <b>5</b>     | <b>63</b>    | <b>22</b>   | <b>17</b>            | <b>1</b> | <b>6205</b> |
| 48         | MC5-4810-INVRET        | MC-VR-5-48        | 57        | 25            | 60        | 5            | 72           | 25          | 19                   | 1        | 6205        |
| <b>54</b>  | <b>MC5-5410-INVRET</b> | <b>MC-VR-5-54</b> | <b>63</b> | <b>28 3/8</b> | <b>66</b> | <b>5</b>     | <b>84</b>    | <b>28</b>   | <b>21</b>            | <b>1</b> | <b>6205</b> |
| 60         | MC5-6010-INVRET        | MC-VR-5-60        | 69        | 31 1/2        | 72        | 5 1/8        | 99           | 31          | 23                   | 1        | 6205        |
| <b>66</b>  | <b>MC5-6610-INVRET</b> | <b>MC-VR-5-66</b> | <b>75</b> | <b>34 7/8</b> | <b>78</b> | <b>5 1/8</b> | <b>108</b>   | <b>33</b>   | <b>25</b>            | <b>1</b> | <b>6205</b> |

### 6" ROLL

| BELT WIDTH | IDLER PART NUMBER      | ROLL PART NUMBER  | A         | B             | C         | D            | IDLER WEIGHT | ROLL WEIGHT | ROLL ROTATING WEIGHT | SHAFT Ø  | BRG TYPE    |
|------------|------------------------|-------------------|-----------|---------------|-----------|--------------|--------------|-------------|----------------------|----------|-------------|
| 24         | MC6-2410-INVRET        | MC-VR-6-24        | 33        | 11 3/4        | 36        | 5 3/8        | 45           | 16          | 13                   | 1        | 6205        |
| <b>30</b>  | <b>MC6-3010-INVRET</b> | <b>MC-VR-6-30</b> | <b>39</b> | <b>15 3/4</b> | <b>42</b> | <b>5 3/8</b> | <b>53</b>    | <b>20</b>   | <b>16</b>            | <b>1</b> | <b>6205</b> |
| 36         | MC6-3610-INVRET        | MC-VR-6-36        | 45        | 18 3/4        | 48        | 5 3/8        | 62           | 23          | 19                   | 1        | 6205        |
| <b>42</b>  | <b>MC6-4210-INVRET</b> | <b>MC-VR-6-42</b> | <b>51</b> | <b>22</b>     | <b>54</b> | <b>5 1/2</b> | <b>71</b>    | <b>26</b>   | <b>21</b>            | <b>1</b> | <b>6205</b> |
| 48         | MC6-4810-INVRET        | MC-VR-6-48        | 57        | 25            | 60        | 5 1/2        | 82           | 30          | 24                   | 1        | 6205        |
| <b>54</b>  | <b>MC6-5410-INVRET</b> | <b>MC-VR-6-54</b> | <b>63</b> | <b>28 3/8</b> | <b>66</b> | <b>5 1/2</b> | <b>95</b>    | <b>33</b>   | <b>27</b>            | <b>1</b> | <b>6205</b> |
| 60         | MC6-6010-INVRET        | MC-VR-6-60        | 69        | 31 1/2        | 72        | 5 1/2        | 111          | 37          | 30                   | 1        | 6205        |
| <b>66</b>  | <b>MC6-6610-INVRET</b> | <b>MC-VR-6-66</b> | <b>75</b> | <b>34 7/8</b> | <b>78</b> | <b>5 1/2</b> | <b>126</b>   | <b>41</b>   | <b>33</b>            | <b>1</b> | <b>6205</b> |

#### NOTES :

1. Also available with wide mounting centers = A + 6"
2. Dimensions in Inches, Weights in lbs