

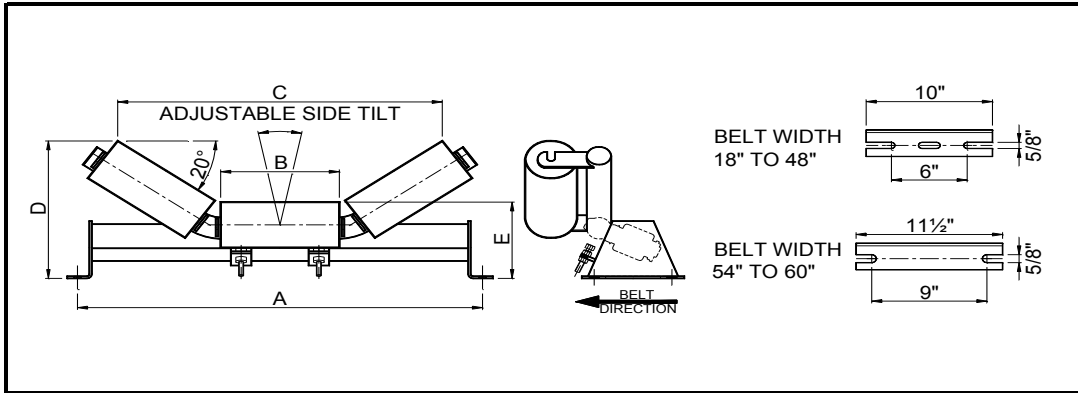

20° TROUGH 'BELT TAMER'



5" ROLL

BELT WIDTH	IDLER PART NUMBER	ROLL PART NUMBER	A	B	C	D	E 1/4" ±	IDLER WEIGHT	ROLL WEIGHT	ROLL ROTATING WEIGHT	SHAFT Ø	BRG TYPE
18	MC5-1820-TBT	MC-TR-5-18	27	7 1/2	22 1/2	11 3/4	9	46	10	8	1	6205
24	MC5-2420-TBT	MC-TR-5-24	33	9 1/2	28 1/4	12 1/2	9	54	12	9	1	6205
30	MC5-3020-TBT	MC-TR-5-30	39	11 3/8	34	13 1/4	9	63	13	10	1	6205
36	MC5-3620-TBT	MC-TR-5-36	45	13 3/8	39 1/2	13 3/4	9	71	15	12	1	6205
42	MC5-4220-TBT	MC-TR-5-42	51	15 3/8	45 1/4	15	9 1/2	80	17	13	1	6205
48	MC5-4820-TBT	MC-TR-5-48	57	17 3/4	52	15 3/4	9 1/2	88	19	15	1	6205
54	MC5-5420-TBT	MC-TR-5-54	63	19 3/4	57 3/4	16 3/4	9 3/4	111	20	16	1	6205
60	MC5-6020-TBT	MC-TR-5-60	69	22	64 1/2	17 1/2	9 3/4	124	22	17	1	6205

6" ROLL

BELT WIDTH	IDLER PART NUMBER	ROLL PART NUMBER	A	B	C	D	E 1/4" ±	IDLER WEIGHT	ROLL WEIGHT	ROLL ROTATING WEIGHT	SHAFT Ø	BRG TYPE
24	MC6-2420-TBT	MC-TR-6-24	33	9 3/8	27 1/2	13	9 1/2	61	14	11	1	6205
30	MC6-3020-TBT	MC-TR-6-30	39	11 1/8	33 1/4	13 3/4	9 1/2	71	16	13	1	6205
36	MC6-3620-TBT	MC-TR-6-36	45	12 1/8	38 3/4	14 1/4	9 1/2	79	18	15	1	6205
42	MC6-4220-TBT	MC-TR-6-42	51	14 1/8	44 1/2	15 1/2	10	90	20	16	1	6205
48	MC6-4820-TBT	MC-TR-6-48	57	15 1/8	51 1/4	16 1/4	10	99	22	18	1	6205
54	MC6-5420-TBT	MC-TR-6-54	63	22 7/8	57	17 1/4	10 1/4	122	24	20	1	6205
60	MC6-6020-TBT	MC-TR-6-60	69	26 2/8	63 3/4	18	10 1/4	144	29	24	1	6205

NOTES :

1. These idlers also available with 20°, 35° and 45° trough angles
2. Also available with wide mounting centers = A + 6"
3. Trough idlers have 3 equal length fully interchangeable rollers.
4. The part number for a frame only is the idler part number with the suffix FR
5. Dimensions in Inches, Weights in lbs
6. Note actual belt height will be approximately 5/8" larger than standard for correct tamer operation

NB. The CEMA C standard for bolt centers is 6" for 18" to 36" belts, and 7-1/2" for 42" to 48" belts.

Our slots are open-ended allowing full compatibility from 18" to 48" belts, for 6" and larger than 7-1/2" bolt centers.

There is an additional central slot allowing for a single bolt option on 18" and up to 48" belt widths.

Information subject to change without notice. Certified information available upon request